



ROTOVALVE LIGHT: technical characteristics

- Valve body and Rotor in stainless steel 1.4404 (AISI 316L) or in advanced plastic FDA approved.
- Gasket in silicone, EPDM, FKM (Viton®) or PTFE: All elastomers are FDA approved (CFR § 177.2600).
- PTFE bushings.
- All Components in stainless steel EN 1.4301 (AISI 304).
- Finish: inside high polish [$Ra < 0,1 \mu m$], outside satin [$Ra < 0,8 \mu m$].
- Drive: rotary pneumatic actuator.

ROTOVALVE LIGHT



The **RotoValve Light** is the solution offered by SteriValves to improve product flow and build-ups in the download phase. The alternating movement of the blades (0° - 180°) allows a constant and regular feed. Differently to traditional rotary valves the oscillating movement of the rotor avoids the unwished demixing of the product.

Thanks to its compartmented design, the **RotoValve Light** is a volumetric dosage system of the product in the process phase. **RotoValve Light** offers many essential features that are important to pharmaceutical manufacturers and any industry requiring high-level sanitary equipment.









Stainless Steel EN 1.4404 (AISI 316L) and high polish ($RA < 0,1 \mu m$) interior finishes provide smooth wipe down friendly surfaces. The sanitary, light weighing quick disconnect clamps make it easy to disassemble **Rotovalve Light** for cleaning and routine maintenance. However **RotoValve Light** is produced according to cGMP and is suitable for CIP/SIP applications. The **RotoValve Light** is also available with a stainless steel control panel to set up rotor stops and speed variations. The **RotoValve Light** is also part of the modular system offered by SteriValves. This system allows the interchangeability of all the components pertaining to the range of sanitary valves.

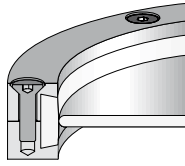
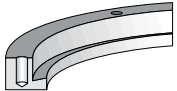
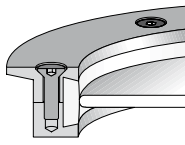
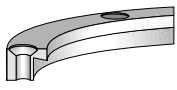
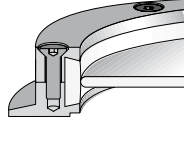

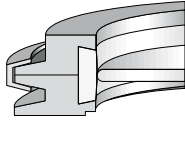
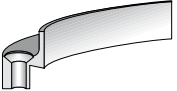
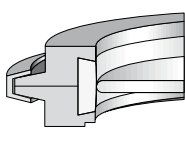
ROTOVALVE LIGHT APPLICATIONS

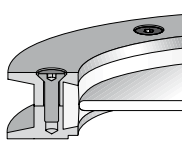
RotoValve Light is very useful in providing metered gravity flow of granules and powders and can suit a wide range of applications. **RotoValve Light** is commonly used in pharmaceutical, dairy and cosmetic industries but also in pilot test plants because offers superior material flow eliminating bridging and compaction.

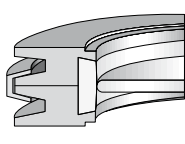
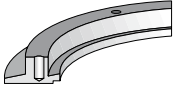
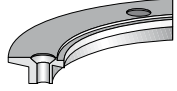
Using a **RotoValve Light** with load cells, a batch weight can be correctly dispensed by each movement or the feed rate constantly controlled. **RotoValve** is the ideal solution for compression machines, fillers, mills and weighing stations. **RotoValve Light** is performed according to CGMP and like all other valves of our modular system is suitable for CIP/SIP applications.

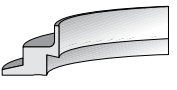
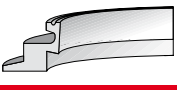
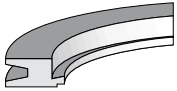
TYPES	COMPONENTS
 RTV SX	 HSB N
 RTV BX	 HST N
 RTV CX	 HSB C
 RTV CR	 HST C
 RTV SR	 HSB T
 RTV DX	 HST T
 RTV DR	 HCB N
	 HCT N
	 HSR N
	 HSR C
	 HSR T
	 HCR N

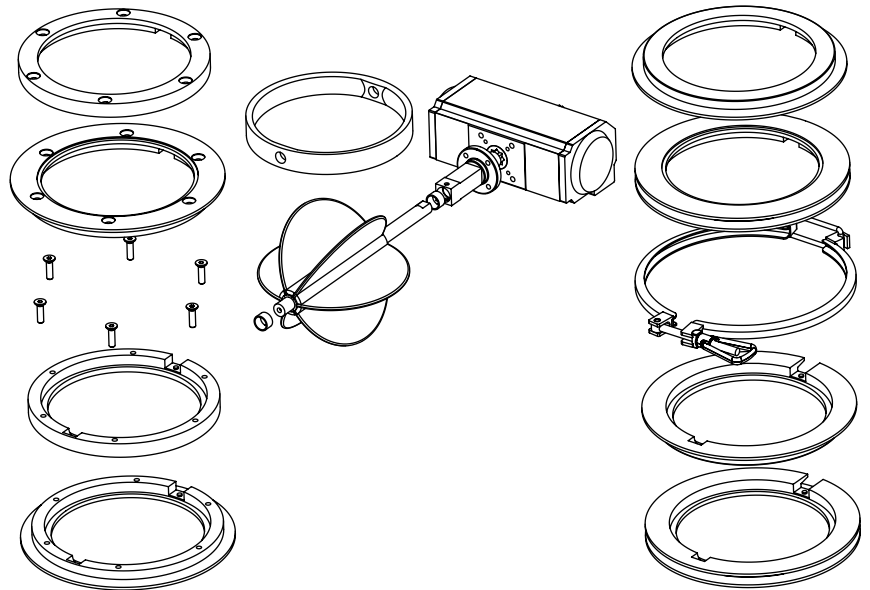

ROTOVALVE LIGHT DIMENSION

ND	D1	D2	F	L	øA
80	130	145	36	120	□10ø15
100	150	180	36	130	□10ø15
150	200	230	40	165	□10ø18
200	250	280	40	190	□14ø18
250	300	330	45	225	□14ø22
300	350	380	45	250	□14ø22
350	420	450	65	290	□22ø30
400	470	500	65	315	□22ø30

