



ROTOVALVE HEAVY: technical characteristics

- Valve body in stainless steel 1.4404 (AISI 316L).
- Bushings in ERTALYTE TX FDA approved.
- Finish: inside high polish ($Ra < 0,1 \mu m$), outside satin ($Ra < 0,8 \mu m$).
- Drive: Pneumatic or electric gear motor.

ROTOVALVE HEAVY

The **RotoValve Heavy** is a valve which task is to feed and dose the products in the pharmaceutical process (powders, granules). Its shape is compact and its design is highly sanitary. The **RotoValve Heavy** offers many advantages for utilization in the food and pharmaceutical field.

This valve hasn't got any gaskets, so it is suitable for applications where the wearing out of the seal could cause problems.

It can be actuated through a pneumatic gear motor or an electric gear motor. Accuracy and capacity can be determined by the customer (blades numbers; volume of each pocket; the connections can all be customized). It has a labyrinth sealing, that generates itself through the blades and the body of the valve. Sterivalves is able to supply, upon customer request, the automatic PLC to guide the valve.





ROTOVALVE HEAVY APPLICATIONS

- Compression machines;
- Fillers;
- Mixers;
- Cell loads;
- And whenever there is a need to feed and dose a flow.

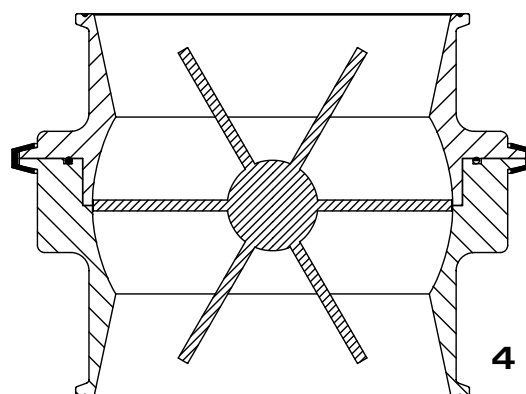
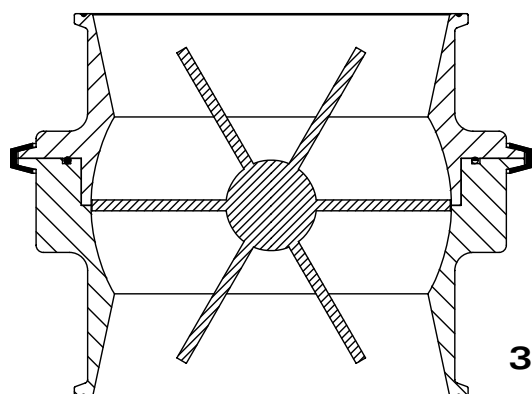
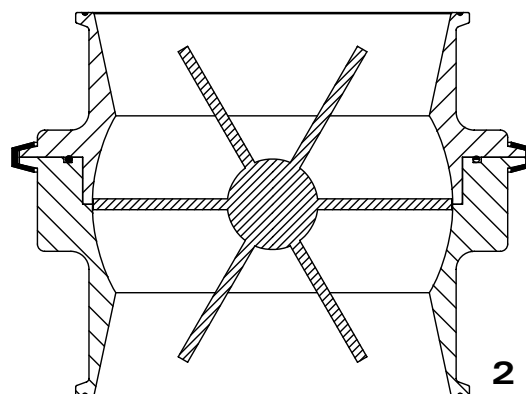
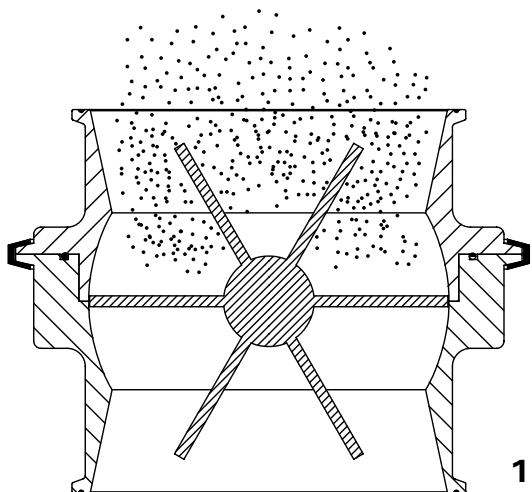

ROTOVALVE HEAVY DIMENSION

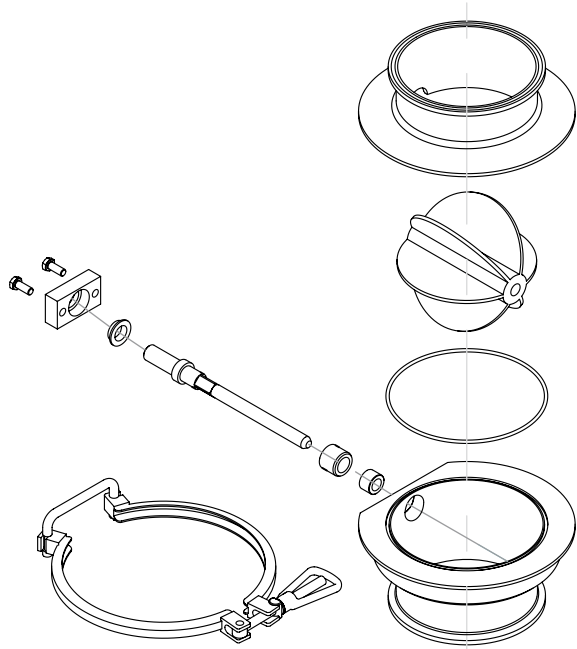

ND	A	B
100	107	TC 4"
150	160	TC 6"
200	212	TC 8"
250	255	TC 10"
300	300	TC 12"

